

2012 Dodge or Ram Truck RAM 3500 Chassis Cab Truck 4WD L6-6.7L DSL Turbo

Vehicle» Engine, Cooling and Exhaust» Cooling System» Service and Repair » Filling

STANDARD PROCEDURE - FILLING

Special Tools:

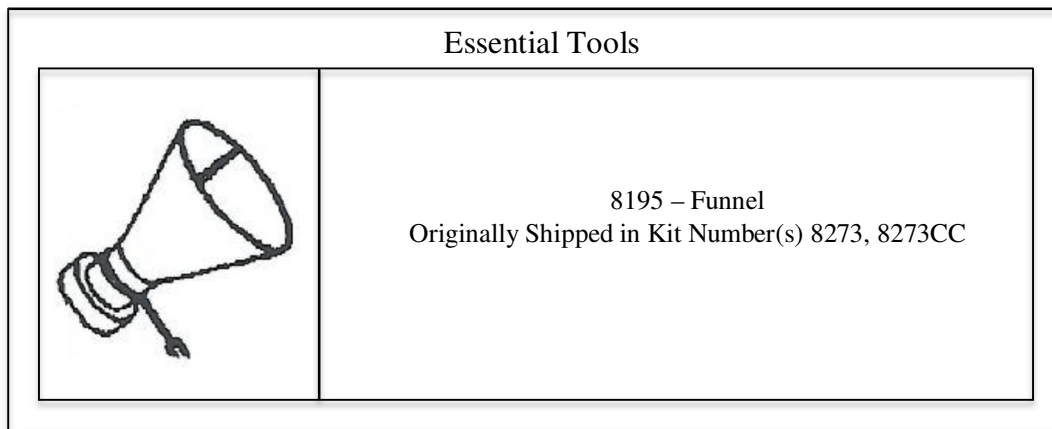

**WARNING:** ANTIFREEZE COOLANT IS HARMFUL IF SWALLOWED OR INHALED. IF SWALLOWED, DRINK TWO GLASSES OF WATER AND INDUCE VOMITING. IF INHALED, MOVE TO FRESH AIR AREA. SEEK MEDICAL ATTENTION IMMEDIATELY. DO NOT STORE IN OPEN OR UNMARKED CONTAINERS. WASH SKIN AND CLOTHING THOROUGHLY AFTER COMING IN CONTACT WITH ETHYLENE GLYCOL. KEEP OUT OF REACH OF CHILDREN. DISPOSE OF GLYCOL BASED COOLANT PROPERLY. CONTACT YOUR DEALER OR GOVERNMENT AGENCY FOR LOCATION OF COLLECTION CENTER IN YOUR AREA. DO NOT OPEN A COOLING SYSTEM WHEN THE ENGINE IS AT OPERATING TEMPERATURE OR HOT UNDER PRESSURE; PERSONAL INJURY CAN RESULT. AVOID RADIATOR COOLING FAN AND OTHER MOVING COMPONENTS WHEN ENGINE COMPARTMENT RELATED SERVICE IS PERFORMED; PERSONAL INJURY CAN RESULT.

**WARNING:** WEAR APPROPRIATE EYE AND HAND PROTECTION WHEN PERFORMING THIS PROCEDURE.

**CAUTION:** Do not use well water or suspect water supply in cooling system. A 50/50 mixture of the recommended antifreeze coolant and distilled water is recommended.

**NOTE:** Cooling system fill procedure is critical to overall cooling system performance.

**NOTE:** Make sure all hoses are connected and radiator draincock is closed. Draincock should be hand tightened only.

## 6.7L

**CAUTION:** All air must be purged from the 6.7L engine when refilling the cooling system. Failure to do so can cause EGR Cooler cracking which can lead to catastrophic engine and exhaust system damage.

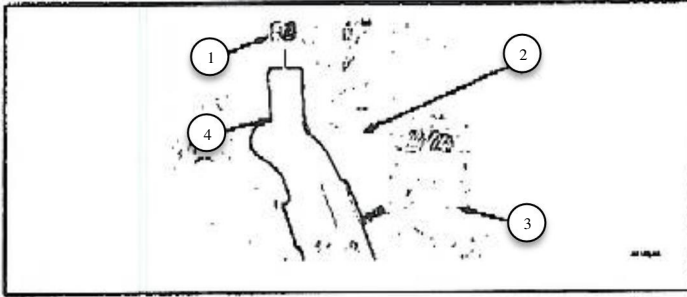

1. Close radiator drain plug.
2. Remove the vent fitting (1) located near the EGR cooler (2).
3. If using funnel 8195:
  - a. Remove cooling system pressure cap. Attach Filling Aid Funnel (8195) , to coolant pressure container filler neck.
  - b. Use the supplied clip to pinch overflow hose.
  - c. Pour coolant into the larger section of Filling Aid Funnel (the smaller section of funnel is to allow air to escape).
  - d. Continue filling until a steady stream of coolant flows from the vent hole.
  - e. Install vent fitting when coolant is free of bubbles.
  - f. Tighten the bleed plug to 6 Nm (55 in. lbs.).
  - g. Remove clip from overflow hose.
  - h. Allow coolant in Filling Aid Funnel to drain into overflow chamber of pressure container.
  - i. Remove Filling Aid Funnel. (8195)
  - j. Install the pressure cap.

**NOTE:** The diesel engine is equipped with two one-way check valves (jiggle pins). The check valves are used as a servicing feature and will vent air when the system is being filled. Water pressure (or flow) will hold the valves closed.

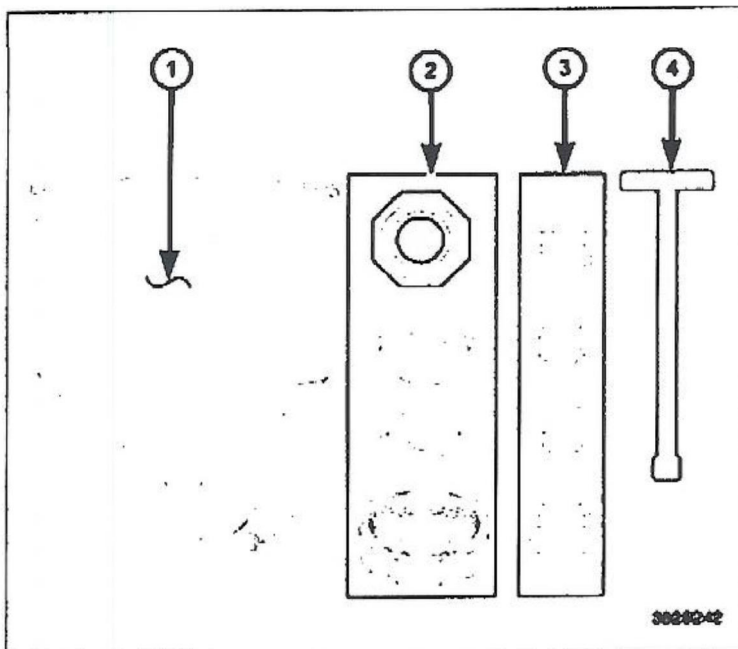

NOTE: The 8195A does not require pinching off the overflow hose. The adapter seal prevents liquid from entering the overflow during coolant fill.

4. If using Special Tool 8195A:
  - a. Select the appropriate fitting extension (3) and locking ring (2) and attach to the fill neck of the cooling system.
  - b. Make sure the adapter seal fits firmly against the inside of the fill neck base to ensure a good seal. After the extension and locking ring are installed, make sure the extension cannot be moved. This will confirm a good seal.
  - c. Attach the funnel (1) to the extension (1) and fill with coolant.
  - d. Add coolant to the funnel. Continue to add coolant until a steady stream of coolant flows from the vent hole.
  - e. Install the vent fitting when coolant is free of bubbles.
  - f. Tighten the vent fitting to 6 Nm (55 in. lbs.).
  - g. Install the stopper (-4) into the funnel base. The stopper will prevent the fluid that is left in the funnel from spilling out when separated from the extension.
  - h. Remove the funnel, extension and locking ring and install the cap.
5. Start and operated the engine. Take the vehicle on a test drive till operating temperature is reached. Shut the engine down and wait till engine is cool.
6. Slowly loosen vent fitting (1) to purge any trapped air. If air is still present, repeat step 3 - 5.
7. Check coolant level in coolant recovery container. Fill to FULL line.
8. The volume of coolant added to the engine must be within 1.5 quarts of the volume drained. If this requirement has not been met, repeat steps 2 - 9.
9. Remove Tool. Install radiator cap.

5.9L

NOTE: The diesel engine is equipped with two one-way check valves (jiggle pins). The check valves are used as a servicing feature and will vent air when the system is being filled. Water pressure (or flow) will hold the valves closed.

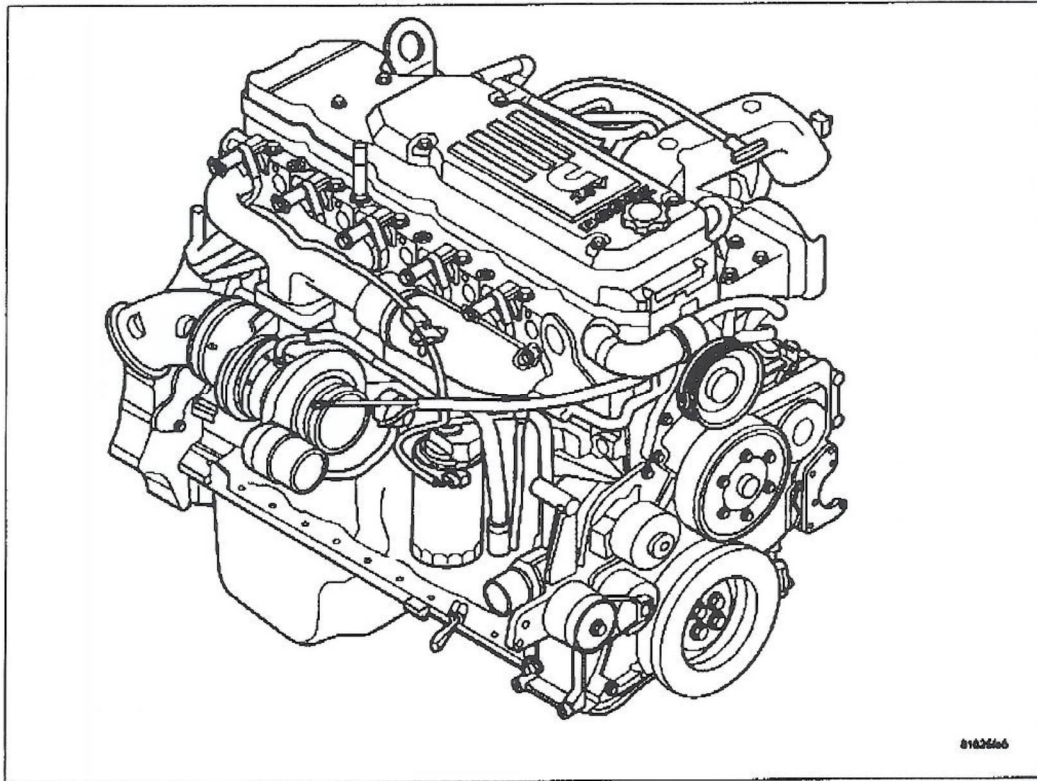

Clean cooling system prior to refilling See: Service and Repair.

1. Close radiator drain plug.
2. If using funnel 8195:
  - a. Remove cooling system pressure cap. Attach Filling Aid Funnel (8195), to coolant pressure container filler neck.
  - b. Use the supplied clip to pinch overflow hose.
  - c. Pour coolant into the larger section of Filling Aid Funnel (the smaller section of funnel is to allow air to escape).
  - d. Add coolant until some coolant remains in the funnel and no more air bubbles appear in the fluid.
  - e. Remove clip from overflow hose.
  - f. Allow coolant in Filling Aid Funnel to drain into overflow chamber of pressure container.
  - g. Remove Filling Aid Funnel. (8195)
  - h. Install the pressure cap.

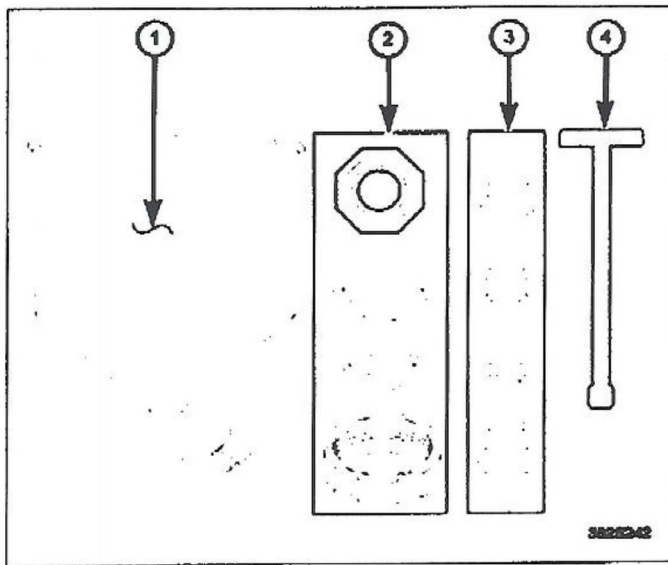

NOTE: The 8195A does not require pinching off the overflow hose. The adapter seal prevents liquid from entering the overflow during coolant fill.

3. If using Special Tool 8195A:

- a. Select the appropriate fitting extension (3) and locking ring (2) and attach to the fill neck of the cooling system.
  - b. Make sure the adapter seal fits firmly against the inside of the fill neck base to ensure a good seal. After the extension and locking ring are installed, make sure the extension cannot be moved. This will confirm a good seal.
  - c. Attach the funnel (1) to the extension (3) and fill with coolant.
  - d. Add coolant to the funnel. Continue to add coolant until it is free of bubbles.
  - e. Install the stopper (4) into the funnel base. The stopper will prevent the fluid that is left in the funnel from spilling out when separated from the extension.
  - f. Remove the funnel, extension and locking ring and install the cap.
4. Fill coolant recovery container to the FULL mark.
  5. Start and operate engine until thermostat opens. Upper radiator hose should be warm to touch.
  6. Accelerate engine from idle to 2500 RPM five times.
  7. Shut off engine, allowing cooling system to settle. Fill coolant recovery container to FULL line.
  8. Start and operate engine. Take vehicle for a test drive till operating temperature is reached.
  9. Shut off engine. Allow engine to cool. Fill coolant recovery container to FULL line.
  10. The volume of coolant added to the engine must be within 1.5 quarts of the volume drained. If this requirement has not been met, repeat steps 1 - 13.
  11. Install radiator cap.

6.7L DIESEL

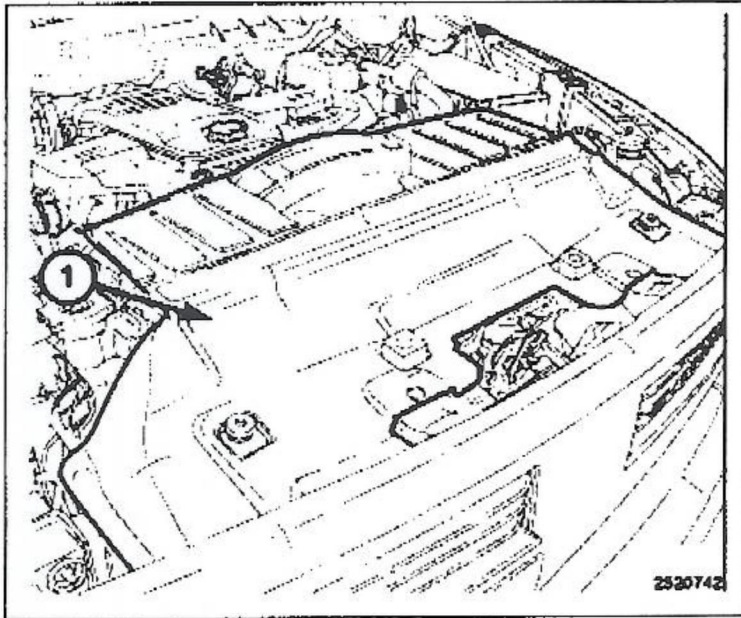

1. Remove the upper radiator shroud (1).
2. Disconnect and isolate the battery negative cable.
3. If equipped, disconnect and isolate the negative battery cable from the auxiliary battery.

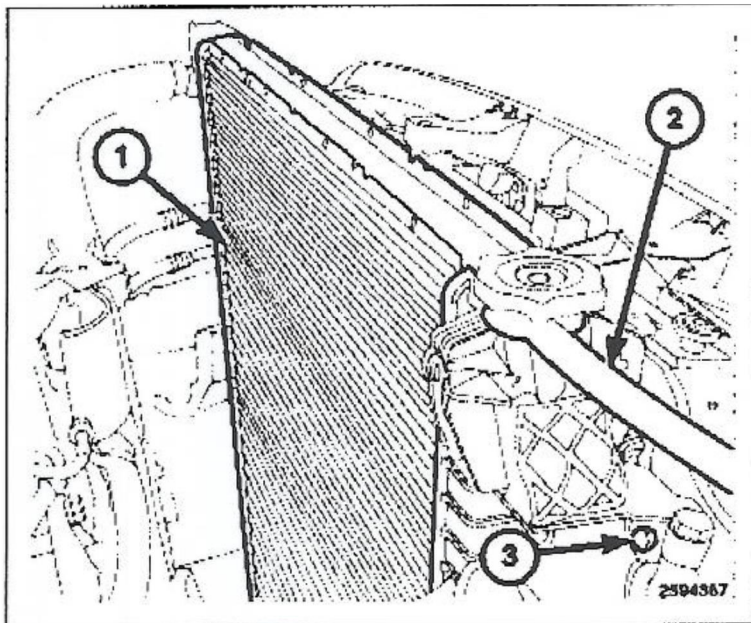

**WARNING:** Do not remove the cylinder block drain plugs or loosen the radiator draincock with the system hot and under pressure. Serious burns from coolant can occur.

4. Drain the cooling system See: Service and Repair.
5. Disconnect the ambient air temperature sensor electrical connector and mass airflow sensor electrical connector (If equipped).
6. Remove air box and turbocharger inlet tube. See: Engine\Air Cleaner Housing\Service and Repair\Air Cleaner Body - Removal.
7. Remove coolant tank hose from the fastening clips located on top of the radiator.
8. Remove the viscous fan and fan shroud. See: Fan Clutch\Service and Repair\Removal and Replacement\Viscous Radiator Fan Clutch - Removal
9. Remove the hose clamps and hoses from radiator.
10. Disconnect the transmission cooler lines at the transmission cooler. The transmission cooler will remain on the radiator and can be removed as an assembly. See: Transmission and Drivetrain\Automatic Transmission\Transaxle\Fluid Line Hose\Service and Repair
11. Remove the two radiator upper mounting bolts.
12. Lift and support the vehicle.
13. Remove the power steering cooler mount bolts and position the power steering cooler out of the way.
14. Lower the vehicle.
15. Tilt the radiator towards the rear of the vehicle and lift it out of the engine compartment. The bottom of the radiator is equipped with two alignment dowels that fit into holes in the lower radiator support panel. Rubber biscuits (insulators) are installed to these dowels. Take care not to damage cooling fins or tubes on the radiator and air conditioning condenser or the electronic viscous fan connector when removing.